

FlarmView and FlarmView57

Flarm collision avoidance display
Version 2.40



LXNAV d.o.o. • Kidričeva 24a, 3000 Celje, Slovenia • tel +386 592 33 400 fax +386 599 33 522
info@lxnav.com • www.lxnav.com

1	Important Notices	4
1.1	Limited Warranty	4
2	Packing Lists	5
3	Basics	6
3.1	LXNAV FlarmView at a Glance	6
3.1.1	Features	6
3.1.1.1	LXNAV FlarmView Features	6
3.1.1.2	LXNAV FlarmView57 Features	6
3.1.2	Interfaces	7
3.1.3	Technical Data	7
4	System Description	8
4.1	Push buttons on FlarmView	8
4.2	Rotary encoder with push button on FlarmView57	8
4.3	Switching on the Unit	8
4.4	User Input	8
4.4.1	Buttons on FlarmView	9
4.4.2	Text Edit Control	9
4.4.3	Selection Control	10
4.4.4	Checkbox and Checkbox List	10
4.4.5	Slider selector	10
4.5	Operating Modes	10
4.6	Main screen	11
4.6.1	Flarm symbols	12
4.6.2	Selecting and switching between targets	12
4.7	Flarm Warning	13
4.8	Traffic list mode	13
4.9	Settings Mode	13
4.9.1	Display	14
4.9.2	Warnings	14
4.9.3	Target	15
4.9.4	Sounds	15
4.9.5	Units	16
4.9.6	Hardware	16
4.9.7	Flarm settings	16
4.9.7.1	Flarm Config	17
4.9.7.2	Aircraft Config	17
4.9.7.3	Flight recorder	17
4.9.7.4	PF IGC readout	18
4.9.7.5	Flarm info	18
4.9.7.6	Licenses	18
4.9.8	Files	19
4.9.9	Password	19
4.9.10	About	19
5	Installation	20
5.1	Installing the LXNAV FlarmView	20
5.2	Installing the FlamView57	20
5.3	Connecting LXNAV FlarmView	21
5.4	Installation of options	21
5.4.1	Ports and Wiring	21
5.4.1.1	LXNAV FlarmView port (RJ11)	21
5.4.1.2	LXNAV FlarmView wiring	22

6	Flarmnet Update	23
7	Firmware Update	24
7.1	Updating LXNAV FlarmView	24
8	Revision History	25

1 Important Notices

The LXNAV FlarmView system is designed for VFR use only as an aid to prudent navigation. All information is presented for reference only. Traffic data and Collision warnings are provided only as an aid to situation awareness.

Information in this document is subject to change without notice. LXNAV reserves the right to change or improve their products and to make changes in the content of this material without obligation to notify any person or organisation of such changes or improvements.



A Yellow triangle is shown for parts of the manual which should be read carefully and are important for operating the LXNAV FlarmView system.



Notes with a red triangle describe procedures that are critical and may result in loss of data or any other critical situation.



A bulb icon is shown when a useful hint is provided to the reader.

1.1 Limited Warranty

This LXNAV FlarmView product is warranted to be free from defects in materials or workmanship for two years from the date of purchase. Within this period, LXNAV will, at its sole option, repair or replace any components that fail in normal use. Such repairs or replacement will be made at no charge to the customer for parts and labour, the customer shall be responsible for any transportation cost. This warranty does not cover failures due to abuse, misuse, accident, or unauthorised alterations or repairs.

THE WARRANTIES AND REMEDIES CONTAINED HEREIN ARE EXCLUSIVE AND IN LIEU OF ALL OTHER WARRANTIES EXPRESSED OR IMPLIED OR STATUTORY, INCLUDING ANY LIABILITY ARISING UNDER ANY WARRANTY OF MERCHANTABILITY OR FITNESS FOR A PARTICULAR PURPOSE, STATUTORY OR OTHERWISE. THIS WARRANTY GIVES YOU SPECIFIC LEGAL RIGHTS, WHICH MAY VARY FROM STATE TO STATE.

IN NO EVENT SHALL LXNAV BE LIABLE FOR ANY INCIDENTAL, SPECIAL, INDIRECT OR CONSEQUENTIAL DAMAGES, WHETHER RESULTING FROM THE USE, MISUSE, OR INABILITY TO USE THIS PRODUCT OR FROM DEFECTS IN THE PRODUCT. Some states do not allow the exclusion of incidental or consequential damages, so the above limitations may not apply to you. LXNAV retains the exclusive right to repair or replace the unit or software, or to offer a full refund of the purchase price, at its sole discretion. SUCH REMEDY SHALL BE YOUR SOLE AND EXCLUSIVE REMEDY FOR ANY BREACH OF WARRANTY.

To obtain warranty service, contact your local LXNAV dealer or contact LXNAV directly.

2 Packing Lists

- LXNAV FlarmView
- FlarmView cable

3 Basics

3.1 LXNAV FlarmView at a Glance

LXNAV FlarmView is Flarm and ADS-B traffic and collision warning display with preloaded FlarmNet database. The 2" QVGA sunlight readable display has 320*240 RGB pixels resolution. For simple and quick manipulation four push buttons on FlarmView and rotary push button on FlarmView57 are used. Flarm View monitors vertical speed and altitude of each object on the screen.



3.1.1 Features

3.1.1.1 LXNAV FlarmView Features

- Extremely bright 2" (5 cm) colour display readable in all sunlight conditions.
- Four push buttons for user input
- Pre-loaded FlarmNet database on removable SD card.
- Standard Flarm RS232 input

3.1.1.2 LXNAV FlarmView57 Features

- Extremely bright 2" (5 cm) colour display readable in all sunlight conditions.
- Rotary push button
- Pre-loaded FlarmNet database on removable SD card.
- Standard Flarm RS232 input

3.1.2 Interfaces

- Flarm / ADS-B port input/output on RS232 level (Standard IGC RJ11 connector)

3.1.3 Technical Data

- Power input 3.3V DC (for FlarmViews serial numbers below 30), all others have 12V-16V DC input.
In case flarm has no 12V output, we have provided an adapter.
- Consumption of LXNAV FlarmView is (0.84W) 70mA@12V
- Weight FlarmView - 25g, FlarmView57 – 97g

4 System Description

4.1 Push buttons on FlarmView

With four push buttons it is possible to zoom, choose between the targets, and adjust FlarmView settings. In some cases, long press to push buttons have some function. On picture below is an example. Long press to upper button will move cursor for one position to the left. Long press to lower button will cancel all changes.

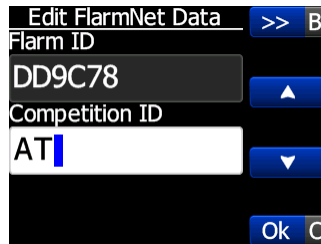

4.2 Rotary encoder with push button on FlarmView57

Using rotary switch is even easier than four buttons. With rotating knob, user can select between the targets, edit numbers, names... Short press has confirmation function (ENTER or OK), long press has (CANCEL or ESC) function. Changing between different zoom levels and pages is possible, if you push and rotate together.

4.3 Switching on the Unit

The unit is switched on immediately after it receives gets power supply from an external Flarm/ADS-B device.

On the welcome screen information about version and serial number is displayed.

4.4 User Input

The LXNAV FlarmView user interface consists of many dialogues, which have different input controls. They are designed to make input of names, parameters, etc., as easy as possible. Input controls can be summarised as:

- Text editor
- Spin controls (Selection control)
- Checkboxes
- Slider control

To move the function from one control to another, use **up** or **down** buttons. By pressing the **Edit** button access to the control that is displayed is possible.

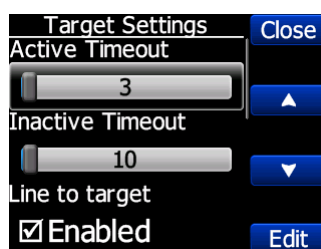

In FlarmView57 up and down means rotating left and right the knob, Short press is same as **Edit**, long push is same as **Close**

4.4.1 Buttons on FlarmView

Buttons have dynamically set functions. When you press a button, on the button side, will appear a blue labels, with the action assigned to that button in that context.

On main screen, top button always performs the function of switching between pages. Short press will cycle in one direction between pages, long press will cycle in the opposite direction between pages. A number of pages look similar initially as the cycling between them simply change the zoom level. The screen will momentary will be updated to reflect the new zoom level. The number in a zoom level icon shows us the outer circle radius (2km – depends on distance units setting). Inner circle is half of that distance.

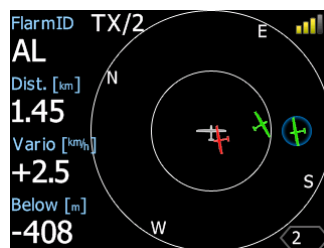

Middle buttons help with target selection by cycling through available targets. Lower button has EDIT function, where we can edit/view the currently selected target.

4.4.2 Text Edit Control

The Text Editor is used to input an alphanumeric string; the picture below shows typical options when editing text. Use the up/down button to change the value at the current cursor position.

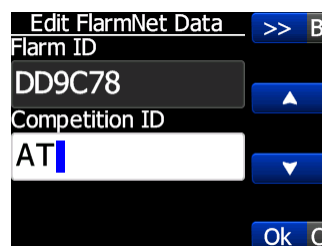

Push button **next** will move cursor right. Long press on **next**, will move cursor left. At last character position, push button will confirm edited value, long press **Ok C** will cancel editing and exit that control. If Long press is available, part of button label is in Gray color. For example above, top button's long press >> **B** has back function. Bottom button's long press has Cancel function. Flarm ID field is not editable, because it's unique flarm identification number.

On FlarmView57, we can enter in Edit mode with short press, rotating knob we can change the characters, short press will confirm current character and jump to the next position. Long press will finish editing that field. With push and rotate, we can move cursor left and right.

4.4.3 Selection Control

Selection boxes, also known as combo boxes, are used to select a value from a list of predefined values. Use the up/down buttons to select the appropriate value.

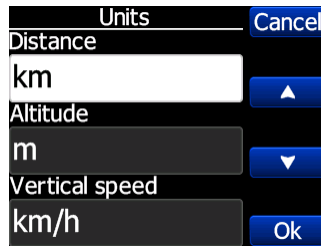

4.4.4 Checkbox and Checkbox List

A checkbox enables or disables a particular parameter. Press **EDIT** button to toggle the value. If an option is enabled a check mark will be shown, otherwise an empty rectangle will be displayed.

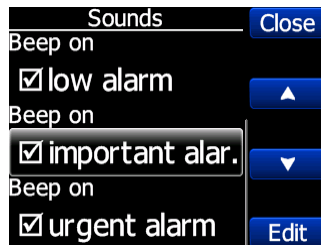

4.4.5 Slider selector

Some values like volume and brightness are displayed as a slider

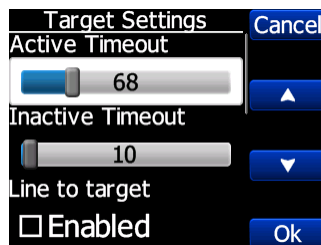

With **Edit** you can activate slider control, then **up/down** buttons you can select the preferred value and confirm it with the **Ok** push button.

4.5 Operating Modes

LXNAV FlarmView has four operating pages. Main radar screen with different zoom levels, Flarm traffic list and Setting Page. The fourth page (**Flarm watch**) is displayed automatically if Flarm detects a potential collision situation and issues a warning.



- **Main radar screen**, shows all visible objects and their information (ID, distance, vertical speed and altitude), status of flarm (TX/2)
- **Flarm Traffic list** is displayed traffic in textual format.
- **Settings**, setup of the whole system
- **Flarm Watch** shows the direction of any threat.

4.6 Main screen

Description of LXNAV FlarmView Main Screen is shown on next picture.

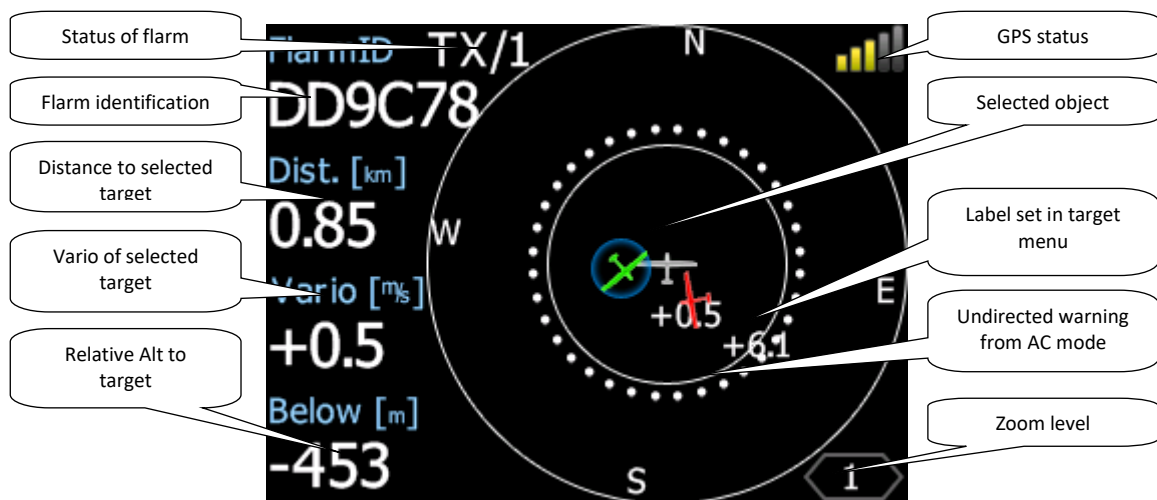

Status of Flarm TX/2, means, that flarm device transmits data, 2 means, that Flarm receives data from two Flarm devices.

Flarm identification is 6 digit hexadecimal number

GPS status indicates the status of Flarm's GPS receiver, number of painted bars counts number of satellites that flarm gps receiver receives. Green bars indicates GPS 3D status, yellow means GPS 2D, red GPS BAD, indication N.C. means that Flarm View does not receive anything from Flarm.





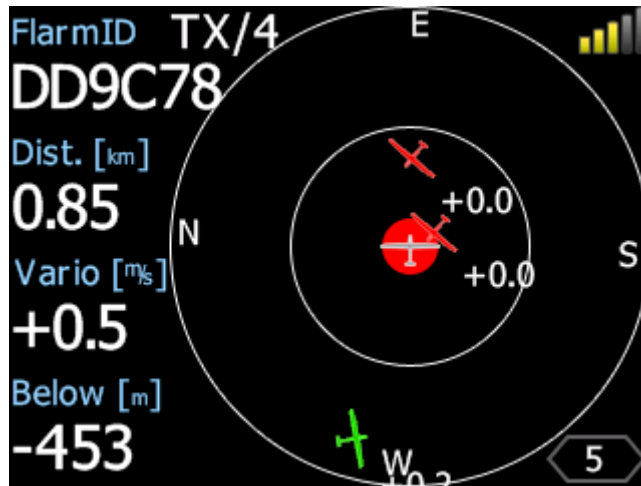







Zoom level tells us what is the zoom setting on radar

In case undirected warning is so close, that we cant display as described above, warning looks like on following picture:



All targets are displayed as a glider symbols. User can change that symbol to another type. It's also possible to change object color, depending on relative altitude to us. All received targets (Flarm or PCAS) are marked with same type of symbol except undirected targets, for which we don't know from which direction they are coming from. Flarm targets can be separated only by their ID.

4.6.1 Flarm symbols

- | | | | |
|---|-------------|---|------------------|
|  | Unknown |  | Para Glider |
|  | Glider |  | Powered Aircraft |
|  | Tow plane |  | Jet Aircraft |
|  | Helicopter |  | Balloon |
|  | Parachute |  | Airship |
|  | Drop plane |  | UAV |
|  | Hang glider | | |

4.6.2 Selecting and switching between targets

Target could be selected using Up/Down (middle two) buttons. If target disappears when it's selected, FlarmView will still indicate some information about last selected target. Information about distance, altitude and vario will disappear. If target will appear back, we will trace it again. In case that we have enabled function Lock to nearest target, selection of targets will not be possible (See Ch.4.9.3)

4.7 Flarm Warning

If Flarm warnings are enabled the following is a typical screen display. First two are normal flarm warnings, third one is for undirected/PCAS warning, Last one is for obstacle warning.

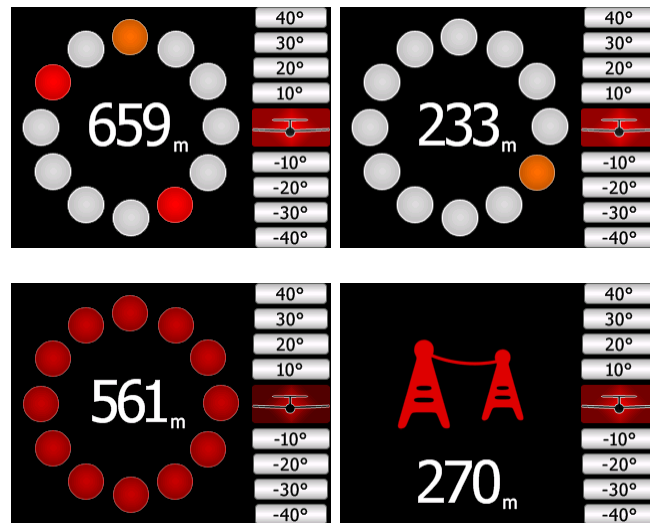

The screen indicates relative position of threat. In the first image two gliders are approaching from left side at the same altitude and one from back right, the second screen one glider is approaching from right side (4'o clock), third screen is an example of undirected warning (AC mode). Middle number shows horizontal distance to the target, last picture indicates obstacle warning.

4.8 Traffic list mode

On this page all traffic is displayed in list form. Buttons have similar functionality as on Main page. In this list we can also see inactive targets, this are targets, which we lost their signals. They will remain on list for time set in setup for target inactive timeout (which is configurable). If target is included in FlarmNet database or UserDatabase, it will appear on list under user friendly name (eg. Competition Sign (CD, AL)). If the target is not on the FlarmNet or UserDatabase, it will be displayed with its FlarmId code.

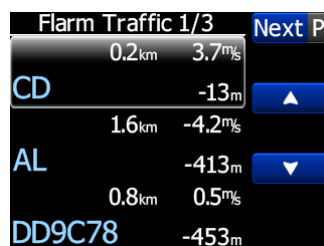

4.9 Settings Mode

In the setup menu users can configure the LXNAV FlarmView. Use up/down to select the appropriate setup item and press the **Select** button to enter a menu. A dialogue or sub-menu will open.



4.9.1 Display

The display menu controls colour scheme and what is displayed on the screen as well as button behaviour.

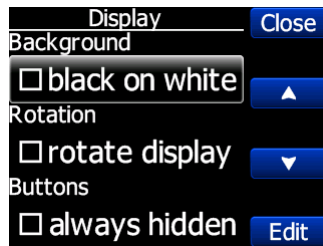

- For better readability, the background can be set to Black or White

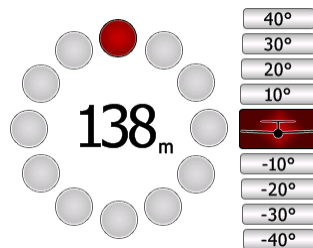

- If you want to have the buttons on left side the complete screen can be rotated.
- If "always hidden" is checked then the button labels are not displayed on main screens.

4.9.2 Warnings

Warnings can be enabled for three different levels (low, important and urgent), separately A/C (undirected warnings can be enabled), also a distance of A/C warning, where will be displayed flarm watch. If Alert on A/C mode is disabled, A/C mode distance is not applicable.

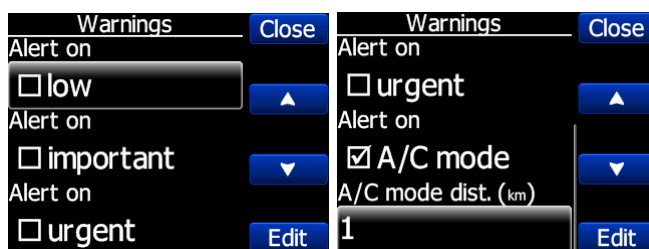

Please keep in mind, that bad A/C receiver or false A/C information can be distracting on FlarmView. To avoid such situation, you can, at any time, uncheck alerts on A/C mode.



First 3 minutes there won't be any warnings.

The warnings are classified into three levels (See Flarm manual for details on www.flarm.com)

- First level (Low) approximately 18 seconds before predicted collision
- Second level (Important) approximately 13 seconds before predicted collision
- Third level (Urgent) approximately 8 seconds before predicted collision.

4.9.3 Target



Active timeout adjusts, remaining time of glider on map after last seen.

Inactive timeout adjusts, remaining time of inactive gliders on the list. Inactive gliders are gliders, where we lost a signal of them, after Active timeout, they became inactive and remains only on the list.

If glider vertical distance is less than 100m (330ft), then glider will be painted with **near glider color**. Gliders with vertical distances above that, will be painted with above setting and below 100m (330ft) will be painted with below setting.

Zoom mode can be set to automatic (zoom to the target) or manual.

If **Target label** is active, near glider will be displayed chosen value.

Show A/C range Shows A/C ring on flarm radar screen

Lock on nearest automatically selects nearest target and displays its data. In case, that you want to select another target, it's possible. After 10 seconds, Flarmview will switch back to nearest target.

If none targets is selected **Auto select** will select to new coming target. **Lock on nearest** has higher priority.

4.9.4 Sounds

In the Sounds setup menu volume settings for the LXNAV FlarmView and alarms settings can be modified.

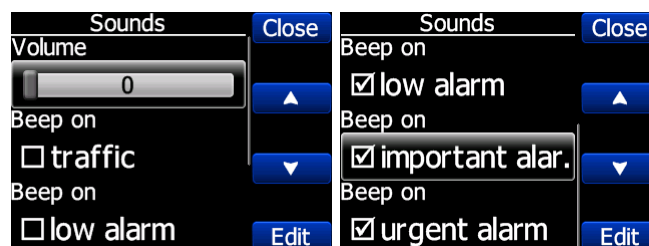

- **Volume** The sounds slider changes the alarm volume.

- **Beep on traffic** FlarmView will notify with short beep a presence of a new Flarm object
- **Beep on low alarm** FlarmView will beep on low level alarms triggered by Flarm
- **Beep on important alarm** FlarmView will beep on important level alarms triggered by Flarm
- **Beep on urgent alarm** FlarmView will beep on critical level alarms (collision) triggered by Flarm

4.9.5 Units

Use this menu to specify units.

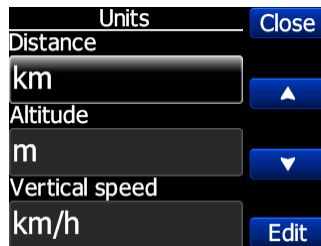

4.9.6 Hardware

On this page we can configure **baudrate** of serial interface. If we use more than one FlarmView connected to Flarm, **Communication** setting must be set to Rx –Slave. That will allow to Master FlarmView to communicate with Flarm in both directions.

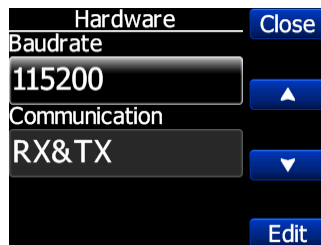

4.9.7 Flarm settings

On this page, we can see information about flarm device and do some configuration about flight recorder, flarm and aircraft.





Those settings will work only if FlarmView is the only one device which communicates with flarm. If other devices are connected (Oudie), there will be a conflict between transmit lines of RS232 from Oudie and FlarmView and communication will not work.

4.9.7.1 Flarm Config

In this menu are all range setups for flarm device.

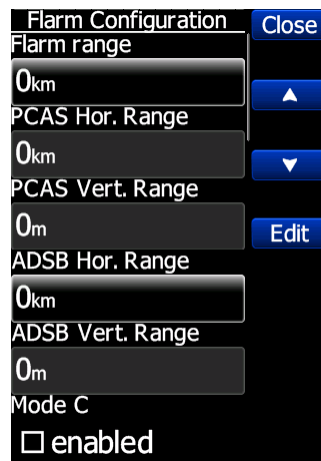

4.9.7.2 Aircraft Config

In Aircraft config menu, user can change the type of aircraft and ICAO Address.

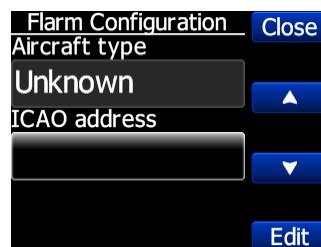

4.9.7.3 Flight recorder

If Flarm has flight recorder, FlarmView can send to flarm all information about pilot and aircraft. This data will be included in the header of IGC file from flarm.



4.9.7.4 PF IGC readout

Pressing to this menu, FlarmView will send command to PowerFlarm, to copy IGC file to USB stick that is plugged in PowerFlarm.



This function works only with PowerFlarm connected.

4.9.7.5 Flarm info

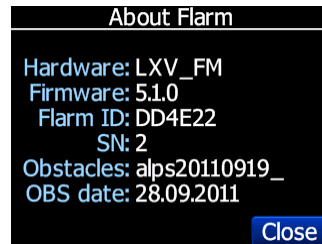

4.9.7.6 Licenses

In this page user can see all options that are active or available for connected Flarm device.

Value	Description
AUD	Audio output connection
AZN	Alert Zone Generator
BARO	Barometric sensor
BAT	Battery compartment or built in batteries
DP2	Second Data Port
ENL	Engine noise level sensor
IGC	Device can be IGC approved
OBST	Device can give obstacle warnings if database is installed and license is valid
TIS	Interface for Garmin TIS
SD	Slot for SD cards
UI	Built-in UI (display, possibly button/knob)
USB	Slot for USB sticks
XPDR	SSR/ADS-B receiver
RFB	Second radio channel for antenna diversity

GND	Device can operate as receive-only ground station
------------	---

4.9.8 Files

In this menu user can download IGC files from Flarm (**DL flight data**), **convert downloaded files to KML** file format (for viewing in Google Earth), **convert FLN** file to FlarmView readable format.



Downloading flight data works only with Flarm devices. PowerFlarm is not able to send flight to FlarmView.

4.9.9 Password

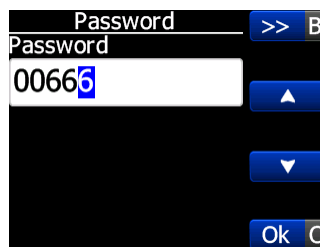

There are several passwords which run specific procedures as listed below:

- **00666** Resets all settings on FlarmView to factory default
- **99999** Will erase all data on Flarm device
- **30000** Will delete Flarmnet user file on FlarmView

4.9.10 About

In about page is information about firmware versions, hardware versions, serial numbers, status of flarm net database.



5 Installation

5.1 Installing the LXNAV FlarmView

The LXNAV FlarmView cutout is very simple. A square hole with dimensions 14mm x 15mm, need to be cut.

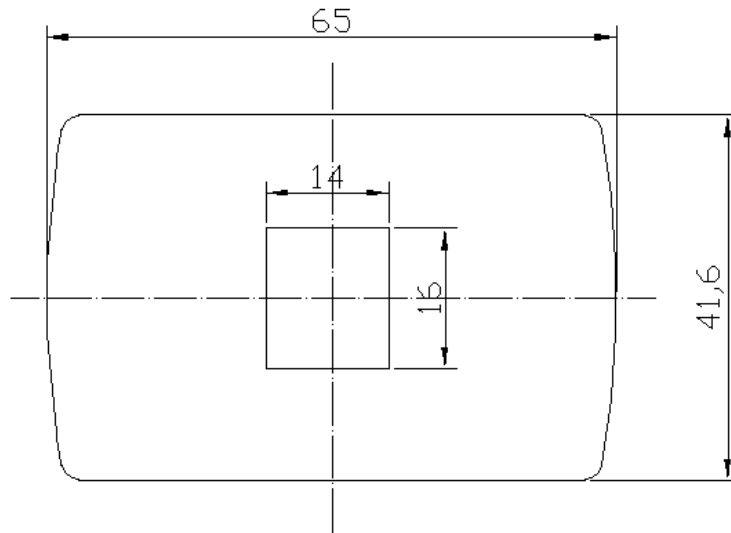

Peel off protection film and stick FlarmView to the instrument panel.

5.2 Installing the FlamView57

The FlamView57 is installed in one standard 57mm (2,5") cutout. If there is none, prepare it according to the picture below.

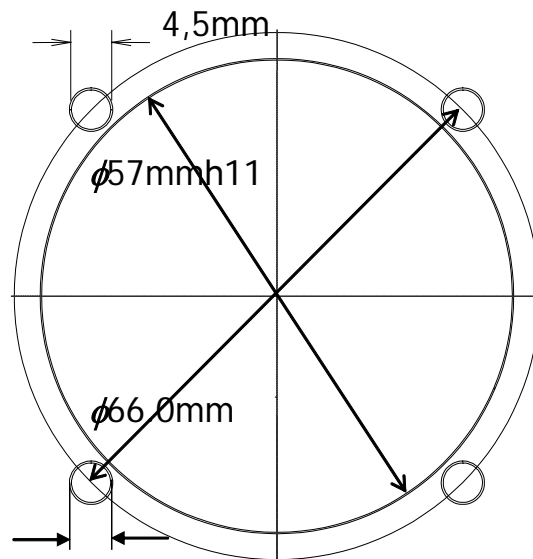

The length of the M4 screws is limited to **6mm!!!!**

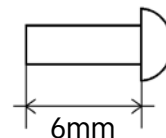

5.3 Connecting LXNAV FlarmView

FlarmView can be connected to any Flarm or ADS-B device with FlarmView cable.

5.4 Installation of options

Optionally more FlarmView devices can be connected through FlarmSplitter.

5.4.1 Ports and Wiring

5.4.1.1 LXNAV FlarmView port (RJ11)

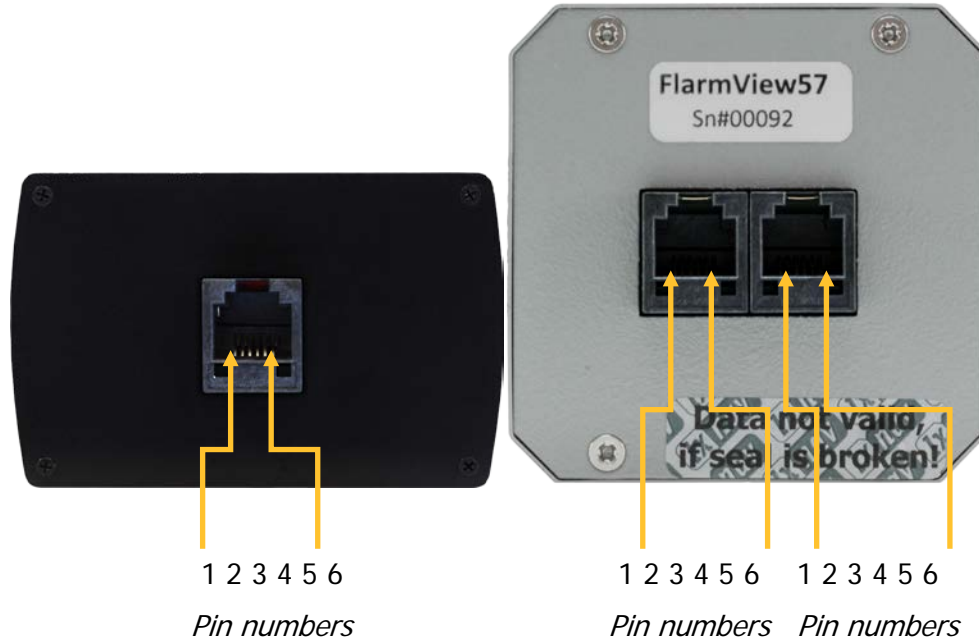

Pin number	Description
1	(Power input) 12VDC (On version 2)
2	(Power input) 3.3VDC (On version 1)
3	GND
4	(input) Data in RS232 – receive line
5	(output) Data out RS232 – transmit line
6	Ground

FlarmView57 is having two equal ports as FlarmView.

5.4.1.2 LXNAV FlarmView wiring

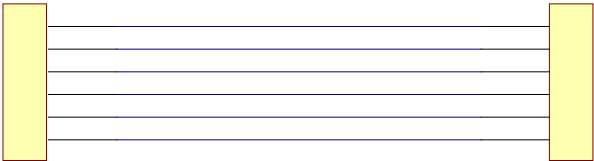

6 Flarmnet Update

Flarm net database can be updated very easily.

- Please visit <http://www.flarmnet.org>
- Download file for LXNAV (LX8000, LX8080, LX9000) or click on following link: <http://www.flarmnet.org/files/lxfile.php>
- FLN type file will be downloaded.
- Use FlarmNetParser application, to convert FLN file to FLX file.
- **The new .flx file must be named "flarm.flx"**
- Copy flarm.flx file to SD card of FlarmView.

On FlarmView is also user.flx file where all user data is stored, which is entered on FlarmView directly. In User data are stored all flarm objects entered/edited by user. This items are probably not in FlarmNet or they are not correct.

7 Firmware Update

Firmware updates of the LXNAV FlarmView can be easily carried out using the SD card. Please visit our webpage www.lxnav.com and check for the updates.

You can also subscribe to a newsletter to receive news about the LXNAV FlarmView automatically.

7.1 Updating LXNAV FlarmView

- Download the latest firmware from our web site, section downloads/firmware <http://www.lxnav.com/download/firmware.html>.
- Copy **fview.fw** file to FlarmView's SD card.
- Turn on FlarmView
- Firmware update will take few seconds.



If update procedure is interrupted of any case, LXNAV FlarmView will not start. It will cycle in bootloader application with red message "Flash integrity failed". Bootloader application is waiting to read the right firmware from SD card. After successful firmware update LXNAV FlarmView will start again.



If FlarmView gives you message "Flash integrity failed", means that firmware update was not successful and need to be repeated.

8 Revision History

June 2012	Initial release of owner manual
August 2012	Release of HW2 with 12V DC power supply input
September 2012	Update of version 0.94 Ch.4.5, Ch 4.6.2. Ch 4.6.3
November 2012	Added new chapter 6
February 2013	Added/updated chapters 4.4.1,4.4.2,4.4.3,4.6,4.6.2,4.8,6
April 2013	Firmware 0.98, Added/updated chapters 4.9.6 4.9.7
September 2013	Firmware 1.00 Added/updated chapters 5.1 4.9.7 4.9.1 4.7
November 2013	Firmware 1.01 Added new product FlarmView57 chapters 3.1.1.2 4.2, 5.2
September 2014	Updated Ch.5.4.1.1
November 2016	Firmware 2.34 Updated and added following chapters 4.9.7, 4.9.7.1, 4.9.7.2, 4.9.7.3, 4.9.7.4, 4.9.7.5, 4.9.7.6, 4.9.8,4.9.2
July 2017	Added new chapter 4.6.1, Updated chapter 4.9.3
April 2018	Updated chapter 4.9.2